



Cambridge International Examinations
Cambridge International General Certificate of Secondary Education

CANDIDATE NAME

CENTRE NUMBER

CANDIDATE NUMBER



CAMBRIDGE INTERNATIONAL MATHEMATICS

0607/61

Paper 6 (Extended)

October/November 2016

1 hour 30 minutes

Candidates answer on the Question Paper.

Additional Materials: Graphics Calculator

READ THESE INSTRUCTIONS FIRST

Write your Centre number, candidate number and name on all the work you hand in.

Write in dark blue or black pen.

Do not use staples, paper clips, glue or correction fluid.

You may use an HB pencil for any diagrams or graphs.

DO NOT WRITE IN ANY BARCODES.

Answer both parts **A** and **B**.

You must show all relevant working to gain full marks for correct methods, including sketches.

In this paper you will also be assessed on your ability to provide full reasons and communicate your mathematics clearly and precisely.

At the end of the examination, fasten all your work securely together.

The total number of marks for this paper is 40.

This document consists of **12** printed pages.

Answer **both** parts A and B.

A INVESTIGATION SQUARES ON GRIDS (20 marks)

You are advised to spend no more than 45 minutes on this part.

This investigation looks at the number of squares drawn on a grid.

All squares are drawn using gridlines.

1 (a) Here is a 2 by 2 grid.

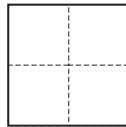

Explain why there are 5 squares on a 2 by 2 grid.

.....

.....

(b) Here is a 3 by 3 grid.

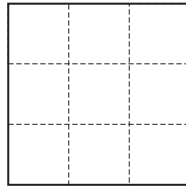

Complete these statements about the numbers of different sized squares on a 3 by 3 grid.

The number of 1 by 1 squares on a 3 by 3 grid is

The number of 2 by 2 squares on a 3 by 3 grid is 4

The number of 3 by 3 squares on a 3 by 3 grid is

So the total number of squares on a 3 by 3 grid is

- (c) Complete these statements about the numbers of different sized squares on a 4 by 4 grid. You may use the grids below to help you.

The number of 1 by 1 squares on a 4 by 4 grid is

The number of 2 by 2 squares on a 4 by 4 grid is

The number of 3 by 3 squares on a 4 by 4 grid is

The number of 4 by 4 squares on a 4 by 4 grid is

So the total number of squares on a 4 by 4 grid is 30

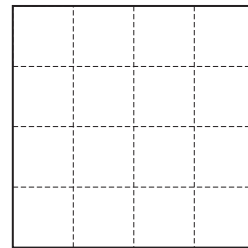
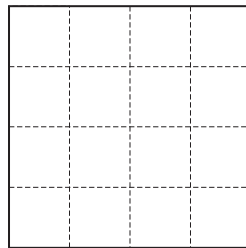
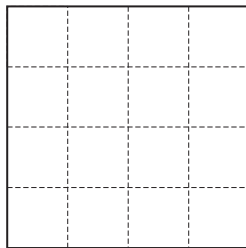

2 (a) Use your results from **question 1** to help you complete this table.

Size of grid	Number of ...						Total number of squares
	1 by 1 squares	2 by 2 squares	3 by 3 squares	4 by 4 squares	5 by 5 squares	6 by 6 squares	
1 by 1	1						
2 by 2							5
3 by 3		4					
4 by 4							30
5 by 5							
6 by 6							

(b) What is the mathematical name for the numbers in the **1 by 1 squares** column?

.....

(c) Work out the **total** number of squares on an 8 by 8 grid.

.....

(d) Write down an expression, in terms of n , for the number of 2 by 2 squares on an n by n grid.

.....

- 3 Here is a formula for the total number of squares, T , on an n by n grid.

$$T = \frac{n^3}{3} + \frac{n^2}{2} + cn + d$$

- (a) Find the values of c and d .

- (b) Show that your formula gives a **total** of 385 squares on a 10 by 10 grid.

- (c) The total number of squares on an n by n grid is 1240.

Find the value of n .

.....

- 4 Here is a 1 by 2 grid.



There is a total of 2 squares on a 1 by 2 grid.

Write an expression, in terms of n , for the total number of squares on a 1 by n grid.

.....

- 5 Here is a 2 by 3 grid.



There is a total of 8 squares on a 2 by 3 grid.

- (a) Find the total number of squares on a 2 by 4 grid.

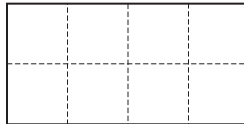

.....

- (b) Complete this table.

Size of grid	Number of ...		Total number of squares (T)
	1 by 1 squares	2 by 2 squares	
2 by 1	2	0	2
2 by 2			
2 by 3			8
2 by 4			
2 by 5			
2 by n			

- 6 Complete this table for 3 by n grids.
You may use the grid below to help you.

Size of grid	Number of ...			Total number of squares (T)
	1 by 1 squares	2 by 2 squares	3 by 3 squares	
3 by 1	3	0	0	3
3 by 2	6	2	0	8
3 by 3	9		1	
3 by 4	12			
3 by 5	15			
3 by n	$3n$			

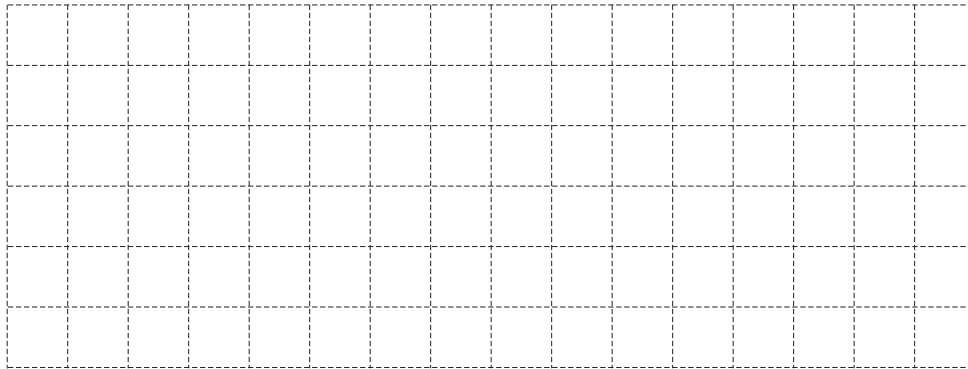

- 7 The expression for T in **question 6** does not work when $n = 1$.

The expression for T for a 4 by n grid is $10n - 10$.

For what values of n will the expression for T for a 4 by n grid not give the correct total?

.....

B MODELLING**MEASURING ROD (20 marks)**

You are advised to spend no more than 45 minutes on this part.

You may find some of these formulas useful.

Volume, V , of pyramid, base area A , height h .

$$V = \frac{1}{3}Ah$$

Volume, V , of cylinder of radius r , height h .

$$V = \pi r^2 h$$

Volume, V , of cone of radius r , height h .

$$V = \frac{1}{3}\pi r^2 h$$

Volume, V , of sphere of radius r .

$$V = \frac{4}{3}\pi r^3$$

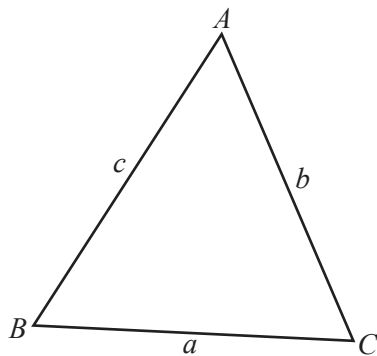

$$\text{Area} = \frac{1}{2}ab \sin C$$

Jim has a tank for oil, shown in the picture.

He uses a measuring rod to put in the top of the tank to find the amount of oil.

This investigation is about how Jim marks the measuring rod.

Here is some information about the tank.

Length	1770 mm
Width	1030 mm
Capacity	1235 litres

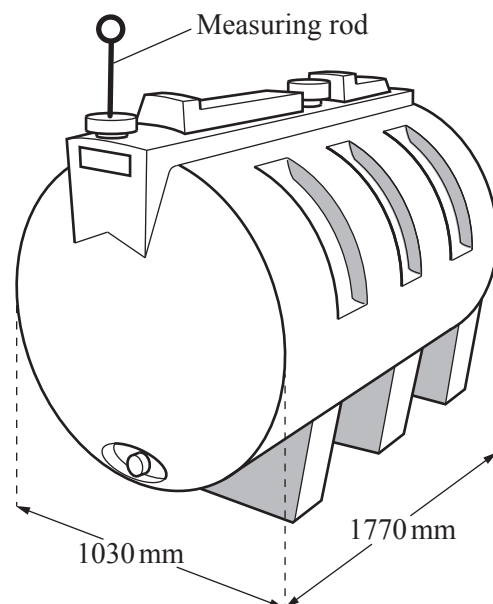

Jim decides to model the volume of oil in his tank.

- 1 (a) Select the shape that Jim should use for the model.

cuboid cylinder sphere cone pyramid circle

.....

- (b) Jim uses a capacity of 1200 litres and a width of 100 cm.

For his model, show that the length of the tank is 153 cm, correct to the nearest centimetre.

- 2 (a) Give a practical reason why the length of his measuring rod should be more than 100 cm.

.....

- (b) This is a cross-section of the tank showing the measuring rod and some oil.

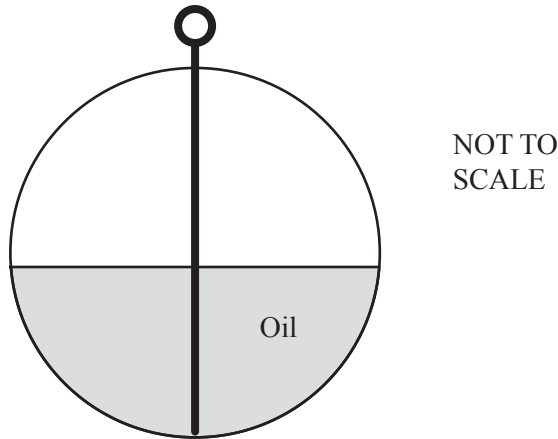

- (i) The tank contains 600 litres of oil.

Find how many centimetres from **the bottom** of the measuring rod Jim should mark “600 litres”.

.....

- (ii) Jim now wants to mark “300 litres” on the measuring rod.

Explain why he should **not** mark this point halfway between the bottom of the measuring rod and the “600 litres” mark.

.....

- 3 Jim works out the distance, d cm, where “300 litres” should be marked on the measuring rod.

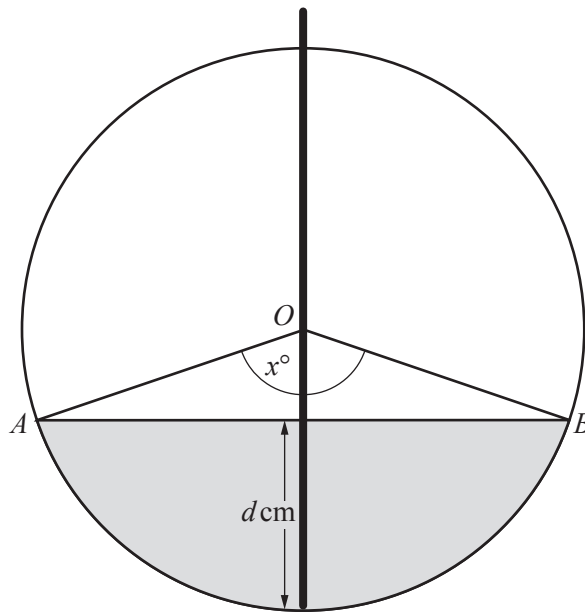

NOT TO
SCALE

O is the centre of the cross section and OA and OB are radii.
 x° is the angle between OA and OB .

He uses this method.

$$\text{Shaded area} = \text{Area of sector } OAB - \text{area of triangle } OAB$$

- (a) Show that an expression for the area of triangle OAB is $1250 \sin x^\circ \text{ cm}^2$.
- (b) Show that an expression for the area of sector OAB is approximately $21.8x \text{ cm}^2$.
- (c) Write down an expression, in terms of x , for the area of the shaded segment.

- (d) Using your result from **question 1(b)** rounded to the nearest centimetre **and** your result from **question 3(c)**, show that a model for the volume of oil, $V \text{ cm}^3$, is approximately

$$V = 3340x - 191\,000 \sin x^\circ.$$

- (e) On the axes, sketch the graph of this model.



- (f) When the tank contains exactly 300 litres of oil, use the model to find

- (i) the value of x ,

.....

- (ii) the value of d , the distance from the bottom of the measuring rod.

.....

- (g) Write down the distance from the bottom of the measuring rod to the “900 litres” mark.

.....

Question 4 is printed on the next page.

4 Jim buys oil when the tank contains 100 litres of oil.

Work out the distance from the bottom of the measuring rod to where “100 litres” should be marked.

.....

Permission to reproduce items where third-party owned material protected by copyright is included has been sought and cleared where possible. Every reasonable effort has been made by the publisher (UCLES) to trace copyright holders, but if any items requiring clearance have unwittingly been included, the publisher will be pleased to make amends at the earliest possible opportunity.

To avoid the issue of disclosure of answer-related information to candidates, all copyright acknowledgements are reproduced online in the Cambridge International Examinations Copyright Acknowledgements Booklet. This is produced for each series of examinations and is freely available to download at www.cie.org.uk after the live examination series.

Cambridge International Examinations is part of the Cambridge Assessment Group. Cambridge Assessment is the brand name of University of Cambridge Local Examinations Syndicate (UCLES), which is itself a department of the University of Cambridge.